

'TAF3' - Series [Flare] Boiler Tube Expanders

3 Plain Rollers
3 Flare Rollers

- ❑ Offset flare rolls eliminates ridges
- ❑ Rolls retained in cage when mandrel is removed

Tristar offers solutions to overcome any installation problem.

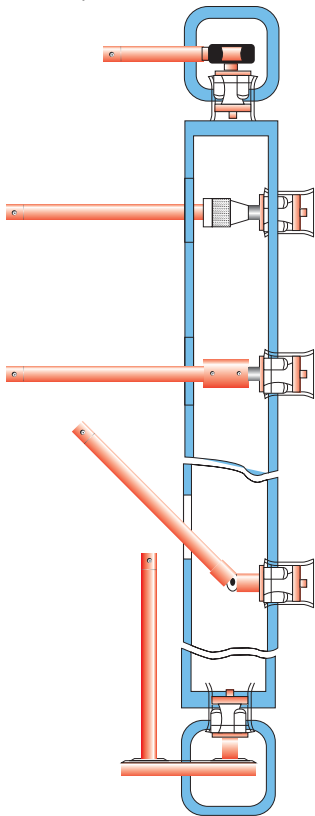

The various drive accessories developed are designed for optimum productivity and operator ease

TUBE SIZE				Min I.D. Tool Enters	Max Expansion of Tool	TUBE EXPANDER MODEL						
O.D. inch	THK GA.	O.D. inch	THK GA.			Tube Sheet Thickness Range						
				mm	inch	mm	inch	1/2" to 7/8"	3/4" to 1.1/8"	1.1/8" to 1.5/8"	1.5/8" to 2.1/8"	2.1/8" to 2.5/8"
				Tube Sheet Thickness Codes >				2	3	4	5	6
7/8	15	1	10	18.1	0.712	20.4	0.803	TAF3-31/2	TAF3-31/3			
	16			18.4	0.724	20.7	0.814	TAF3-32/2	TAF3-32/3			
	17	1	11	18.8	0.740	21.1	0.830	TAF3-33/2	TAF3-33/3			
	18	1	12	19.4	0.763	21.6	0.850	TAF3-34/2	TAF3-34/3			
	19 - 20	1.1/8	8	19.7	0.775	22.3	0.877	TAF3-35/2	TAF3-35/3			
1	13			20.1	0.791	22.4	0.881	TAF3-36/2	TAF3-36/3			
	14	1.1/8	9	20.6	0.811	23.1	0.909	TAF3-37/2	TAF3-37/3	TAF3-37/4		
	15 - 16	1.1/8	10	21.3	0.838	23.8	0.937	TAF3-38/2	TAF3-38/3	TAF3-38/4		
	17 - 18	1.1/8	11	22.0	0.866	24.5	0.964	TAF3-39/2	TAF3-39/3	TAF3-39/4		
	19 - 20	1.1/8	12	22.4	0.881	25.0	0.984	TAF3-40/2	TAF3-40/3	TAF3-40/4		
1.1/4	8	1.1/8	13	23.3	0.917	25.9	1.019	TAF3-41/2	TAF3-41/3	TAF3-41/4		
	9	1.1/8	14	23.8	0.937	26.5	1.043	TAF3-42/2	TAF3-42/3	TAF3-42/4		
	10	1.1/8	15 - 16	24.4	0.960	27.2	1.070	TAF3-43/2	TAF3-43/3	TAF3-43/4		
	11			25.2	0.992	28.0	1.102	TAF3-44/2	TAF3-44/3	TAF3-44/4		
	12			25.7	1.011	28.5	1.122	TAF3-45/2	TAF3-45/3	TAF3-45/4		
	13	1.3/8	8	26.1	1.027	28.8	1.133	TAF3-46/2	TAF3-46/3	TAF3-46/4		
	14			26.4	1.039	29.2	1.149	TAF3-47/2	TAF3-47/3	TAF3-47/4		
	15	1.3/8	9	26.9	1.059	29.7	1.169	TAF3-48/2	TAF3-48/3	TAF3-48/4		
	16	1.3/8	10	27.6	1.086	30.4	1.196	TAF3-49/2	TAF3-49/3	TAF3-49/4	TAF3-49/5	TAF3-49/6
1.1/2	7	1.3/8	11	28.3	1.114	31.2	1.228	TAF3-50/2	TAF3-50/3	TAF3-50/4	TAF3-50/5	TAF3-50/6
	8	1.3/8	12	28.8	1.133	31.7	1.248	TAF3-51/2	TAF3-51/3	TAF3-51/4	TAF3-51/5	TAF3-51/6
	9	1.3/8	13 - 14	29.5	1.161	33.4	1.134	TAF3-52/2	TAF3-52/3	TAF3-52/4	TAF3-52/5	TAF3-52/6
	10	1.3/8	15 - 16	30.0	1.181	34.1	1.342	TAF3-53/2	TAF3-53/3	TAF3-53/4	TAF3-53/5	TAF3-53/6
	11 - 12			30.6	1.204	34.8	1.370	TAF3-54/2	TAF3-54/3	TAF3-54/4	TAF3-54/5	TAF3-54/6

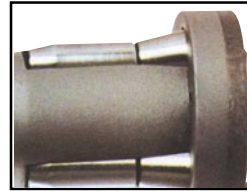

SPARE ROLLER SET MODEL					SPARE MANDREL MODEL			
1/2" to 7/8"	3/4" to 1.1/8"	1.1/8" to 1.5/8"	1.5/8" to 2.1/8"	2.1/8" to 2.5/8"	Drum Type	Header Type	Short Series 5.1/8"	SQ
2	3	4	5	6				
152-F3	153-F3				TDM-11			3/8" <input type="checkbox"/>
152-F3	153-F3				TDM-12			
162-F3	163-F3							
202-F3	203-F3							
172-F3	173-F3				TDM-13			
182-F3	183-F3				TDM-12			3/8" <input type="checkbox"/>
182-F3	183-F3	184-F3			TDM-13	THM-13	TSM-13	
192-F3	193-F3	194-F3						
212-F3	213-F3	214-F3						
212-F3	213-F3	214-F3			TDM-14	THM-14	TSM-14	
222-F3	223-F3	224-F3						1/2" <input type="checkbox"/>
232-F3	233-F3	234-F3			TDM-15	THM-15	TSM-15	
242-F3	243-F3	244-F3						
262-F3	263-F3	264-F3			TDM-16	THM-16	TSM-16	
272-F3	273-F3	274-F3						
312-F3	313-F3	314-F3						1/2" <input type="checkbox"/>
282-F3	283-F3	284-F3			TDM-17	THM-17	TSM-17	
292-F3	293-F3	294-F3						
302-F3	303-F3	304-F3	305-F3	306-F3				
302-F3	303-F3	304-F3	305-F3	306-F3	TDM-18	THM-18	TSM-18	
322-F3	323-F3	324-F3	325-F3	326-F3				1/2" <input type="checkbox"/>
282-F3	283-F3	284-F3	285-F3	286-F3	TDM-20	THM-20	TSM-20	
292-F3	293-F3	294-F3	295-F3	296-F3				
302-F3	303-F3	304-F3	305-F3	306-F3				

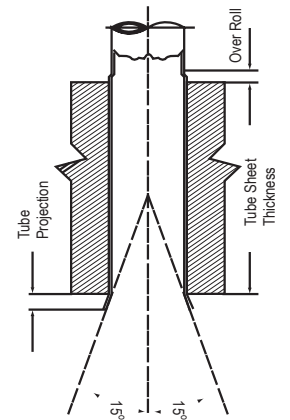

Can be supplied with 1 flare and 2 plane rollers

'TAF3' - Series [Flare] Boiler Tube Expanders

3 Plain Rollers
3 Flare Rollers

- ❑ Offset flare rolls eliminates ridges
- ❑ Rolls retained in cage when mandrel is removed

Tristar offers solutions to overcome any installation problem.

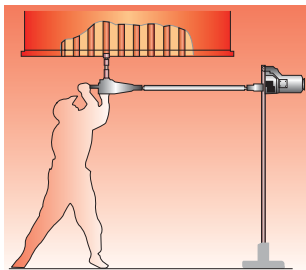

Drive in conjunction with telescopic shaft coupled to a right angled gear drive makes tube installations easier.

TUBE SIZE				Min I.D. Tool Enters		Max Expansion of Tool		TUBE EXPANDER MODEL				
								Tube Sheet Thickness Range				
O.D inch	THK bwg	O.D. inch	THK bwg	mm	inch	mm	inch	1/2" to 7/8"	3/4" to 1.1/8"	1.1/8" to 1.5/8"	1.5/8" to 2.1/8"	2.1/8" to 2.5/8"
				Tube Sheet Thickness Codes >				2	3	4	5	6
1.1/2	13	1.3/4	5	31.4	1.236	35.6	1.401	TAF3-55/2	TAF3-55/3	TAF3-55/4	TAF3-55/5	TAF3-55/6
	14 - 15	1.3/4	6	32.6	1.283	36.8	1.448	TAF3-56/2	TAF3-56/3	TAF3-56/4	TAF3-56/5	TAF3-56/6
2		1.3/4	7	33.4	1.314	38.1	1.500	TAF3-57/2	TAF3-57/3	TAF3-57/4	TAF3-57/5	TAF3-57/6
		1.3/4	8	34.2	1.346	38.7	1.523	TAF3-58/2	TAF3-58/3	TAF3-58/4	TAF3-58/5	TAF3-58/6
	3	1.3/4	9 - 10	35.0	1.377	40.6	1.598	TAF3-59/2	TAF3-59/3	TAF3-59/4	TAF3-59/5	TAF3-59/6
	4	1.3/4	11 - 12	36.6	1.440	42.2	1.661	TAF3-60/2	TAF3-60/3	TAF3-60/4	TAF3-60/5	TAF3-60/6
	5 - 6	1.3/4	13 - 14	38.2	1.503	43.8	1.712	TAF3-61/2	TAF3-61/3	TAF3-61/4	TAF3-61/5	TAF3-61/6
	7 - 8	1.3/4	15 - 16	39.8	1.566	45.4	1.787	TAF3-62/2	TAF3-62/3	TAF3-62/4	TAF3-62/5	TAF3-62/6
	9 - 10	2.1/4	3	41.4	1.629	47.0	1.850	TAF3-63/2	TAF3-63/3	TAF3-63/4	TAF3-63/5	TAF3-63/6
	11 - 13	2.1/4	4	42.9	1.688	49.5	1.948	TAF3-64/2	TAF3-64/3	TAF3-64/4	TAF3-64/5	TAF3-64/6
	14 - 16	2.1/4	6 - 7	44.5	1.751	51.1	2.011	TAF3-65/2	TAF3-65/3	TAF3-65/4	TAF3-65/5	TAF3-65/6
	17 - 18	2.1/4	8 - 9	46.1	1.814	52.7	2.074	TAF3-66/2	TAF3-66/3	TAF3-66/4	TAF3-66/5	TAF3-66/6
	2.1/2	3	2.1/4	10 - 11	47.7	1.877	54.3	2.137	TAF3-67/2	TAF3-67/3	TAF3-67/4	TAF3-67/5
	4 - 5	2.1/4	12 - 13	49.3	1.940	55.9	2.200	TAF3-68/2	TAF3-68/3	TAF3-68/4	TAF3-68/5	TAF3-68/6
	6 - 7	2.1/4	14 - 16	50.8	2.200	57.8	2.275	TAF3-69/2	TAF3-69/3	TAF3-69/4	TAF3-69/5	TAF3-69/6
	8 - 9	2.3/4	3	52.4	2.062	59.4	2.338	TAF3-70/2	TAF3-70/3	TAF3-70/4	TAF3-70/5	TAF3-70/6
	10 - 11	2.3/4	4	54.0	2.125	61.0	2.401	TAF3-71/2	TAF3-71/3	TAF3-71/4	TAF3-71/5	TAF3-71/6
	12 - 14	2.3/4	5 - 6	55.6	2.188	64.0	2.519	TAF3-72/2	TAF3-72/3	TAF3-72/4	TAF3-72/5	TAF3-72/6
	15 - 16	2.3/4	7 - 8	57.2	2.251	65.6	2.582	TAF3-73/2	TAF3-73/3	TAF3-73/4	TAF3-73/5	TAF3-73/6
	3	3	2.3/4	9 - 10	58.6	2.307	67.0	2.637	TAF3-74/2	TAF3-74/3	TAF3-74/4	TAF3-74/5
	4	2.3/4	11 - 13	60.4	2.377	68.8	2.708	TAF3-75/2	TAF3-75/3	TAF3-75/4	TAF3-75/5	TAF3-75/6
	5 - 6	2.3/4	14 - 16	62.2	2.448	70.4	2.771	TAF3-76/2	TAF3-76/3	TAF3-76/4	TAF3-76/5	TAF3-76/6
	7 - 8			63.6	2.503	72.0	2.834	TAF3-77/2	TAF3-77/3	TAF3-77/4	TAF3-77/5	TAF3-77/6
	9 - 10	3.1/4	3	65.0	2.559	73.4	2.889	TAF3-78/2	TAF3-78/3	TAF3-78/4	TAF3-78/5	TAF3-78/6

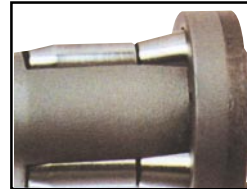

SPARE ROLLER SET MODEL					SPARE MANDREL MODEL			
Tube Sheet Thickness Range					Drum Type	Header Type	Short Series 5.1/8"	SQ
1/2" to 7/8"	3/4" to 1.1/8"	1.1/8" to 1.5/8"	1.5/8" to 2.1/8"	2.1/8" to 2.5/8"				
2	3	4	5	6				
332-F3	333-F3	334-F3	335-F3	336-F3	TDM20	THM-20	TSM-20	1/2"
342-F3	343-F3	344-F3	345-F3	346-F3	TDM-21	THM-21	TSM-21	
362-F3	363-F3	364-F3	365-F3	366-F3				
372-F3	373-F3	374-F3	375-F3	376-F3				3/4"
332-F3	333-F3	334-F3	335-F3	336-F3	TDM-22	THM-22	TSM-22	
372-F3	373-F3	374-F3	375-F3	376-F3				
382-F3	383-F3	384-F3	385-F3	386-F3				
392-F3	393-F3	394-F3	395-F3	396-F3				
402-F3	403-F3	404-F3	405-F3	406-F3				
402-F3	403-F3	404-F3	405-F3	406-F3	TDM-23	THM-23	TSM-23	
412-F3	413-F3	414-F3	415-F3	416-F3				
422-F3	423-F3	424-F3	425-F3	426-F3				
432-F3	433-F3	434-F3	435-F3	436-F3				
442-F3	443-F3	444-F3	445-F3	446-F3				1"
432-F3	433-F3	434-F3	435-F3	436-F3	TDM-24	THM-24	TSM-24	
442-F3	443-F3	444-F3	445-F3	446-F3				
452-F3	453-F3	454-F3	455-F3	456-F3				
472-F3	473-F3	474-F3	475-F3	476-F3				
462-F3	463-F3	464-F3	465-F3	466-F3	TDM-25	THM-25	TSM-25	
472-F3	473-F3	474-F3	475-F3	476-F3				1"
482-F3	483-F3	484-F3	485-F3	486-F3				
492-F3	493-F3	494-F3	495-F3	496-F3				
502-F3	503-F3	504-F3	505-F3	506-F3				
512-F3	513-F3	514-F3	515-F3	516-F3				

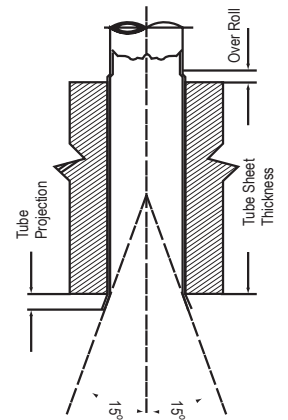

'TAF3' - Series [Flare] Boiler Tube Expanders

3 Plain Rollers
3 Flare Rollers

- ❑ Offset flare rolls eliminates ridges
- ❑ Rolls retained in cage when mandrel is removed

Tristar offers solutions to overcome any installation problem.

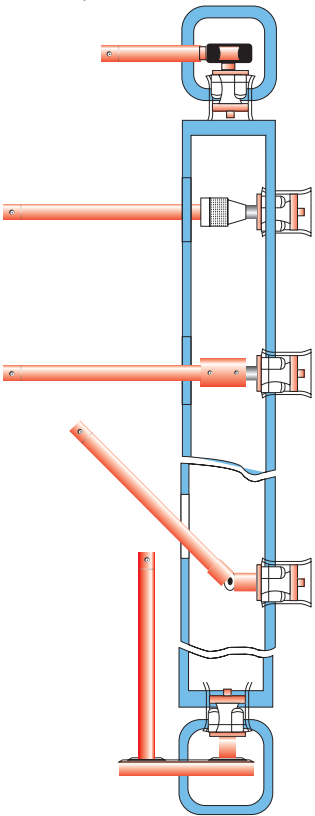

The various drive accessories developed are designed for optimum productivity and operator ease

TUBE SIZE				Min I.D. Tool Enters		Max Expansion of Tool		TUBE EXPANDER MODEL				
								Tube Sheet Thickness Range				
O.D inch	THK bwg	O.D. inch	THK bwg	mm	inch	mm	inch	1/2" to 7/8"	3/4" to 1.1/8"	1.1/8" to 1.5/8"	1.5/8" to 2.1/8"	2.1/8" to 2.5/8"
				Tube Sheet Thickness Codes >				2	3	4	5	6
3	11 - 13	3.1/4	4	66.6	2.622	75.0	2.952	TAF3-79/2	TAF3-79/3	TAF3-79/4	TAF3-79/5	TAF3-79/6
	14 - 16	3.1/4	5 - 6	68.3	2.688	76.9	3.027	TAF3-80/2	TAF3-80/3	TAF3-80/4	TAF3-80/5	TAF3-80/6
3.1/2	2	3.1/4	7 - 8	69.9	2.751	78.5	3.090	TAF3-81/2	TAF3-81/3	TAF3-81/4	TAF3-81/5	TAF3-81/6
	3	3.1/4	9 - 10	71.5	2.814	80.1	3.153	TAF3-82/2	TAF3-82/3	TAF3-82/4	TAF3-82/5	TAF3-82/6
	4	3.1/4	11 - 13	73.1	2.877	81.7	3.216	TAF3-83/2	TAF3-83/3	TAF3-83/4	TAF3-83/5	TAF3-83/6
	5 - 6	3.1/4	14 - 16	74.6	2.937	84.2	3.314	TAF3-84/2	TAF3-84/3	TAF3-84/4	TAF3-84/5	TAF3-84/6
	7 - 8	3.3/4	2	76.2	3.000	85.5	3.366	TAF3-85/2	TAF3-85/3	TAF3-85/4	TAF3-85/5	TAF3-85/6
	9 - 11	3.3/4	3	77.8	3.062	87.4	3.440	TAF3-86/2	TAF3-86/3	TAF3-86/4	TAF3-86/5	TAF3-86/6
	12 - 16	3.3/4	4	79.4	3.125	89.0	3.503	TAF3-87/2	TAF3-87/3	TAF3-87/4	TAF3-87/5	TAF3-87/6
4		3.3/4	5 - 6	81.0	3.188	90.6	3.566	TAF3-88/2	TAF3-88/3	TAF3-88/4	TAF3-88/5	TAF3-88/6
	2	3.3/4	7 - 8	82.6	3.251	92.2	3.629	TAF3-89/2	TAF3-89/3	TAF3-89/4	TAF3-89/5	TAF3-89/6
	3	3.3/4	9 - 10	84.2	3.314	93.8	3.692	TAF3-90/2	TAF3-90/3	TAF3-90/4	TAF3-90/5	TAF3-90/6
	4	3.3/4	11 - 13	85.8	3.377	96.2	3.787	TAF3-91/2	TAF3-91/3	TAF3-91/4	TAF3-91/5	TAF3-91/6
	5 - 6	3.3/4	14 - 16	87.4	3.440	97.8	3.850	TAF3-92/2	TAF3-92/3	TAF3-92/4	TAF3-92/5	TAF3-92/6
	7 - 8	4.1/4	2	89.0	3.503	99.4	3.913	TAF3-93/2	TAF3-93/3	TAF3-93/4	TAF3-93/5	TAF3-93/6
	9 - 11	4.1/4	3	90.4	3.559	100.8	3.968	TAF3-94/2	TAF3-94/3	TAF3-94/4	TAF3-94/5	TAF3-94/6
	12 - 16	4.1/4	4	92.0	3.622	102.4	4.031	TAF3-95/2	TAF3-95/3	TAF3-95/4	TAF3-96/5	TAF3-95/6
		4.1/4	5 - 6	93.4	3.677	103.8	4.086	TAF3-96/2	TAF3-96/3	TAF3-96/4	TAF3-96/5	TAF3-96/6
	4.1/2	2	4.1/4	7 - 8	95.0	3.740	105.4	4.149	TAF3-97/2	TAF3-97/3	TAF3-97/4	TAF3-97/5
3		4.1/4	9 - 11	96.6	3.803	107.0	4.212	TAF3-98/2	TAF3-98/3	TAF3-98/4	TAF3-98/5	TAF3-98/6
4 - 5		4.1/4	11 - 13	98.2	3.866	108.6	4.275	TAF3-99/2	TAF3-99/3	TAF3-99/4	TAF3-99/5	TAF3-99/6
6 - 7				101.2	3.984	110.0	4.330	TAF3-100/2	TAF3-100/3	TAF3-110/4	TAF3-100/5	TAF3-100/6
8 - 9				102.8	4.047	111.6	4.393	TAF3-101/2	TAF3-101/3	TAF3-101/4	TAF3-101/5	TAF3-101/6
10 - 12				104.4	4.110	113.2	4.456	TAF3-102/2	TAF3-102/3	TAF3-102/4	TAF3-102/5	TAF3-102/6

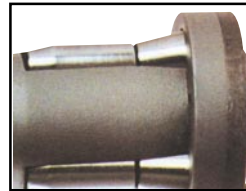

SPARE ROLLER SET MODEL					SPARE MANDREL MODEL			
Tube Sheet Thickness Range					Drum Type	Header Type	Short Series 5.1/8"	SQ
1/2" to 7/8"	3/4" to 1.1/8"	1.1/8" to 1.5/8"	1.5/8" to 2.1/8"	2.1/8" to 2.5/8"				
2	3	4	5	6				
522-F3	523-F3	524-F3	525-F3	526-F3	TDM-25	THM-25	TSM-25	
512-F3	513-F3	514-F3	515-F3	516-F3	TDM-26	THM-26	TSM-26	
522-F3	523-F3	524-F3	525-F3	526-F3				
532-F3	533-F3	534-F3	535-F3	536-F3				
542-F3	543-F3	544-F3	545-F3	546-F3				
542-F3	543-F3	544-F3	545-F3	546-F3	TDM-27	THM-27	TSM-27	
552-F3	553-F3	554-F3	555-F3	556-F3				
562-F3	563-F3	564-F3	565-F3	566-F3				
572-F3	573-F3	574-F3	575-F3	576-F3				
582-F3	583-F3	584-F3	585-F3	586-F3				
592-F3	593-F3	594-F3	595-F3	596-F3				
602-F3	603-F3	604-F3	605-F3	606-F3				
592-F3	593-F3	594-F3	595-F3	596-F3	TDM-28	THM-28	TSM-28	
602-F3	603-F3	604-F3	605-F3	606-F3				
612-F3	613-F3	614-F3	615-F3	616-F3				
622-F3	623-F3	624-F3	625-F3	626-F3				
632-F3	633-F3	634-F3	635-F3	636-F3				
622-F3	623-F3	624-F3	625-F3	626-F3	TDM-29	THM-29	TSM-29	
632-F3	633-F3	634-F3	635-F3	636-F3				
642-F3	643-F3	644-F3	645-F3	646-F3				
632-F3	633-F3	634-F3	635-F3	636-F3	TDM-30	THM-30	TSM-30	
642-F3	643-F3	644-F3	645-F3	646-F3				
652-F3	653-F3	654-F3	655-F3	656-F3				
662-F3	663-F3	664-F3	665-F3	666-F3				

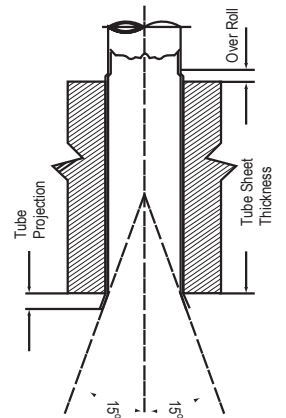

'T - 1000' - Series [Flare] Boiler Tube Expander

3 Plain Rollers
3 Flare Rollers

- Most ideal for inaccessible areas
 - Water boxes
 - Small diameter drums

Tristar offers solutions to overcome any installation problem.

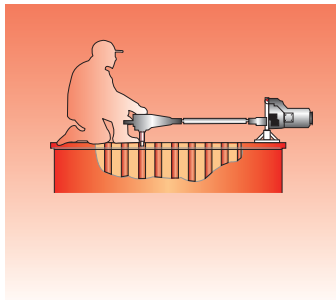

One of our drive systems helps overcome a problem caused by a difficult access...

- Reduces operator fatigue
- Ensures operator safety
- Increases productivity
- Maintains consistent accuracy

TUBE SIZE				Min I.D. Tool Enters	Max Expansion of Tool	TUBE EXPANDER MODEL						
						Tube Sheet Thickness Range						
O.D. inch	THK bwg	O.D. inch	THK bwg	mm	inch	mm	inch	1/2" to 3/4"	7/8" to 1.1/4"	1.3/8" to 1.3/4"	1.7/8" to 2.1/4"	2.3/8" to 2.3/4"
				Tube Sheet Thickness Codes >		3	5	7	9	11		
1	13 - 14			20.0	0.787	23.4	0.921	T1079/3	T1079/5			
	15 - 16			21.0	0.827	24.4	0.961	T1083/3	T1083/5			
1.1/4	7			22.0	0.866	25.5	1.004	T1087/3	T1087/5			
	8 - 9			23.0	0.906	26.5	1.043	T1091/3	T1091/5			
	10			24.0	0.945	28.1	1.105	T1095/3	T1095/5			
	11-13			25.0	0.984	29.0	1.142	T1099/3	T1099/5			
	14 -15			26.0	1.024	30.0	1.181	T1103/3	T1103/5			
1.1/2	16			28.1	1.105	33.0	1.299	T1111/3	T1111/5			
	10-12			31.0	1.221	35.0	1.378	T1118/3	T1118/5			
1.3/4	13-16			33.0	1.300	38.0	1.496	T1126/3	T1126/5			
	8 - 9	2	3	35.0	1.379	40.0	1.575	T1134/3	T1134/5	T1134/7	T1134/9	T1134/11
	10 - 12	2	4 - 5	37.0	1.457	42.5	1.673	T1142/3	T1142/5	T1142/7	T1142/9	T1142/11
2	13 - 16	2	6	39.0	1.536	44.5	1.752	T1150/3	T1150/5	T1150/7	T1150/9	T1150/11
	7 - 9	2.1/4	3	41.0	1.615	47.0	1.850	T1158/3	T1158/5	T1158/7	T1158/9	T1158/11
	10-12	2.1/4	4 - 5	43.0	1.694	49.0	1.929	T1166/3	T1166/5	T1166/7	T1166/9	T1166/11
	13-16	2.1/4	6	45.0	1.772	51.5	2.027	T1174/3	T1174/5	T1174/7	T1174/9	T1174/11
2.1/4	16	2.1/2	3	47.0	1.851	54.0	2.126	T1181/3	T1182/5	T1182/7	T1182/9	T1182/11
	10 - 13	2.1/2	4 - 5	49.0	1.930	56.0	2.205	T1189/3	T1189/5	T1189/7	T1189/9	T1189/11
	14 - 16	2.1/2	6	51.0	2.009	60.0	2.362	T1197/3	T1197/5	T1197/7	T1197/9	T1197/11
2.1/2	7-10			53.0	2.087	62.0	2.441	T1205/3	T1205/5	T1205/7	T1205/9	T1205/11
	11-13	3	2	55.0	2.116	64.0	2.520	T1213/3	T1213/5	T1213/7	T1213/9	T1213/11
	14-16			57.0	2.245	66.0	2.598	T1221/3	T1221/5	T1221/7	T1221/9	T1221/11

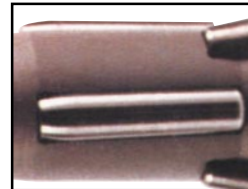

SPARE ROLLER SET MODEL					SPARE MANDREL MODEL		
Tube Sheet Thickness Range					Drum Type	Short Series Mandrels	SQ
1/2" to 3/4"	7/8" to 1.1/4"	1.3/8" to 1.3/4"	1.7/8" to 2.1/4"	2.3/8" to 2.3/4"			
3	5	7	9	11			
0793-FS	0795-FS				TMP-83		1/2" <input type="checkbox"/>
0833-FS	0835-FS						
0873-FS	0875-FS				TMP-91		1/2" <input type="checkbox"/>
0953-FS	0955-FS						
0953-FS	0955-FS				TMP-99		1/2" <input type="checkbox"/>
0993-FS	0995-FS						
1033-FS	1035-FS				TMP-118	TMPS-1,2,3	3/4" <input type="checkbox"/>
1113-FS	1115-FS						
1183-FS	1185-FS				TMP-126	TMPS-2,3,4	3/4" <input type="checkbox"/>
1263-FS	1265-FS						
1263-FS	1265-FS	1267-FS	1269-FS	12611-FS	TMP-134	TMPS-3,4,5	3/4" <input type="checkbox"/>
1423-FS	1425-FS	1427-FS	1429-FS	14211-FS			
1503-FS	1505-FS	1507-FS	1509-FS	15011-FS	TMP-150	TMPS-3,4,5,6	3/4" <input type="checkbox"/>
1583-FS	1585-FS	1587-FS	1589-FS	15811-FS			
1663-FS	1665-FS	1667-FS	1669-FS	16611-FS	TMP-174	TMPS-4,5,6,7,8	3/4" <input type="checkbox"/>
1743-FS	1745-FS	1747-FS	1749-FS	17411-FS			
1813-FS	1815-FS	1817-FS	1819-FS	18111-FS	TMP-197	TMPS-7,8,9,10,11	1" <input type="checkbox"/>
1743-FS	1745-FS	1747-FS	1749-FS	17411-FS			
2053-FS	2055-FS	2057-FS	2059-FS	20511-FS	TMP-221	TMPS-6,7,8,9,10,11	1" <input type="checkbox"/>
2053-FS	2055-FS	2057-FS	2059-FS	20511-FS			
2133-FS	2135-FS	2137-FS	2139-FS	21311-FS	TMP-221	TMPS-7,8,9,10,11,12	1" <input type="checkbox"/>
2213-FS	2215-FS	2217-FS	2219-FS	22111-FS			

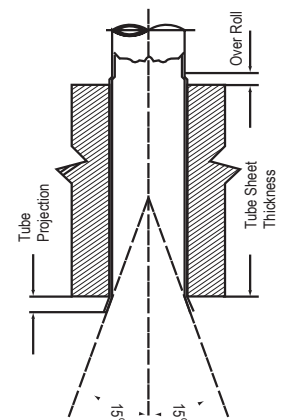

'T - 1000' - Series [Flare] Boiler Tube Expander

3 Plain Rollers
3 Flare Rollers

□ Most ideal for inaccessible areas

- Water boxes
- Small diameter drums

Tristar offers solutions to overcome any installation problem.

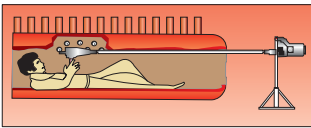

A typical example of an inaccessible area where Tristar drive system ensures..

- Reduced operator fatigue
- Operator safety
- Increased productivity
- Better accessibility

TUBE SIZE				Min I.D. Tool Enters		Max Expansion of Tool		TUBE EXPANDER MODEL				
								Tube Sheet Thickness Range				
O.D. inch	THK bwg	O.D. inch	THK bwg	mm	inch	mm	inch	1/2" to 3/4"	7/8" to 1.1/4"	1.3/8" to 1.3/4"	1.7/8" to 2.1/4"	2.3/8" to 2.3/4"
				Tube Sheet Thickness Codes >				3	5	7	9	11
2.3/4	7 - 9			59.0	2.323	68.0	2.677	T1229/3	T1229/5	T1229/7	T1229/9	T-1229/11
	10 - 12			61.0	2.402	70.0	2.756	T1237/3	T1237/5	T1237/7	T1237/9	T-1237/11
	13 - 16			63.0	2.481	72.0	2.835	T1244/3	T1244/5	T1244/7	T1244/9	T1244/11
3	7 - 8			65.0	2.560	74.0	2.913	T1252/3	T1252/5	T1252/7	T1252/9	T1252/11
	10 - 12			67.0	2.638	76.0	2.992	T1260/3	T1260/5	T1260/7	T1260/9	T1260/11
	13 - 14			69.0	2.717	78.0	3.071	T1268/3	T1268/5	T1268/7	T1268/9	T1268/11
	15 - 16			71.0	2.796	80.0	3.150	T1276/3	T1276/5	T1276/7	T1276/9	T1276/11
3.1/4	7 - 11			73.0	2.874	82.0	3.228	T1284/3	T1284/5	T1284/7	T1284/9	T1284/11
	12 - 14			75.0	2.953	84.0	3.307	T1292/3	T1292/5	T1292/7	T1292/9	T1292/11
	15 - 16	3.1/2	7 - 9	77.0	3.032	86.0	3.386	T1300/3	T1300/5	T1300/7	T1300/9	T1300/11
3.1/2	10 - 12			79.0	3.111	88.0	3.465	T1308/3	T1308/5	T1308/7	T1308/9	T1308/11
	13 - 15			81.0	3.190	92.0	3.622	T1315/3	T1315/5	T1315/7	T1315/9	T1315/11
	16	3.3/4	7 - 8	83.0	3.268	94.0	3.701	T1323/3	T1323/5	T1323/7	T1323/9	T1323/11
3.3/4	9 - 12			85.0	3.347	96.0	3.780	T1331/3	T1331/5	T1331/7	T1331/9	T1331/11
	13 - 16			87.0	3.426	98.0	3.858	T1339/3	T1339/5	T1339/7	T1339/9	T1339/11
4	7 - 8			89.0	3.505	100.0	3.937	T1347/3	T1347/5	T1347/7	T1347/9	T1347/11
	9 - 12			91.0	3.583	102.0	4.016	T1355/3	T1355/5	T1355/7	T1355/9	T1355/11
	13 - 15			93.0	3.662	104.0	4.094	T1363/3	T1363/5	T1363/7	T1363/9	T1363/11
	16	4.1/4	7 - 8	95.0	3.741	106.0	4.173	T1370/3	T1370/5	T1370/7	T1370/9	T1370/11
4.1/4	9 - 11			97.0	3.820	108.0	4.252	T1378/3	T1378/5	T1378/7	T1378/9	T1378/11
	12 - 16			99.0	3.898	110.0	4.331	T1386/3	T1386/5	T1386/7	T1386/9	T1386/11
4.1/2	7 - 14			101.0	3.997	111.0	4.407	T1394/3	T1394/5	T1394/7	T1394/9	T1394/11

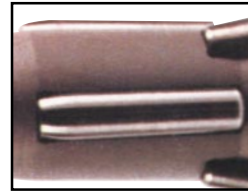

SPARE ROLLER SET MODEL					SPARE MANDREL MODEL			
Tube Sheet Thickness Range					Drum Type	Short Series Mandrels	SQ	
1/2" to 3/4"	7/8" to 1.1/4"	1.3/8" to 1.3/4"	1.7/8" to 2.1/4"	2.3/8" to 2.3/4"				
3	5	7	9	11				
2213-FS	2215-FS	2217-FS	2219-FS	22111-FS	TMP-244	TMPS-8,9,10,11,12,13		
2373-FS	2375-FS	2377-FS	2379-FS	23711-FS				
2523-FS	2525-FS	2527-FS	2529-FS	25211-FS				
2523-FS	2525-FS	2527-FS	2529-FS	25211-FS	TMP-268	TMPS-10,11,12,13,14		
2603-FS	2605-FS	2607-FS	2609-FS	26011-FS				
2683-FS	2685-FS	2687-FS	2689-FS	26811-FS	TMP-300	TMPS-12,13,14,15,16		
2763-FS	2765-FS	2767-FS	2769-FS	27611-FS				
2843-FS	2845-FS	2847-FS	2849-FS	28411-FS				
2923-FS	2925-FS	2927-FS	2929-FS	29211-FS	TMP-347	TMPS-15,16,17,18,19		1" SQ
3153-FS	3155-FS	3157-FS	3159-FS	31511-FS				
3233-FS	3235-FS	3237-FS	3239-FS	32311-FS		TMPS-14,15,16,17,18,19		
3313-FS	3315-FS	3317-FS	3319-FS	33111-FS	TMP-394	TMPS-17,18,19,20,21		
3553-FS	3555-FS	3557-FS	3559-FS	35511-FS				
3633-FS	3635-FS	3637-FS	3639-FS	36311-FS				
3553-FS	3555-FS	3557-FS	3559-FS	35511-FS	TMP-394	TMPS-17,18,19,20,21		
3633-FS	3635-FS	3637-FS	3639-FS	36311-FS				
3703-FS	3705-FS	3707-FS	3709-FS	37011-FS				
3783-FS	3785-FS	3787-FS	3789-FS	37811-FS				
3863-FS	3865-FS	3867-FS	3869-FS	38611-FS				
3943-FS	3945-FS	3947-FS	3949-FS	39411-FS				

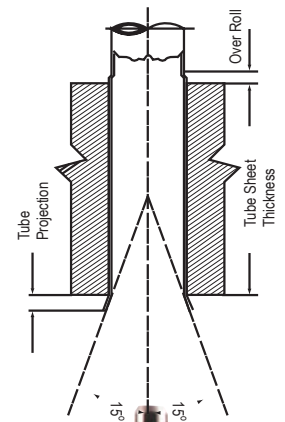

'T - 2000' Series [Flare] Boiler Tube Expander

3 Plain Rollers

3 Flare Rollers

- ❑ Controlled travel of expander
- ❑ Positive depth setting
- ❑ Uniform tight joints
- ❑ In-built thrust bearing

Tristar offers solutions to overcome any installation problem.

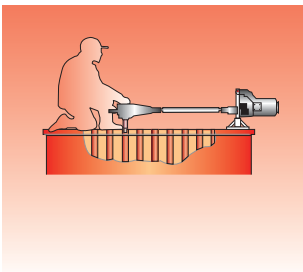

Tristar offers not just tube tools but complete solutions to overcome any installation problem

Our drive systems are designed to overcome most difficult installation problem

TUBE SIZE				Min I.D. Tool Enters		Max Expansion of Tool		TUBE EXPANDER MODEL				
								Tube Sheet Thickness Range				
O.D inch	THK bwg	O.D. inch	THK bwg	mm	inch	mm	inch	1/2" to 3/4"	7/8" to 1.1/4"	1.3/8" to 1.3/4"	1.7/8" to 2.1/4"	2.3/8" to 2.3/4"
Tube Sheet Thickness Codes >								3	5	7	9	11
1	13 - 14			20.0	0.787	23.4	0.921	T2079/3	T2079/5			
	15 - 16			21.0	0.827	24.4	0.961	T2083/3	T2083/5			
1.1/4	7			22.0	0.866	25.5	1.004	T2087/3	T2087/5			
	8 - 9			23.0	0.906	26.5	1.043	T2091/3	T2091/5			
	10			24.0	0.945	28.1	1.105	T2095/3	T2095/5			
	11 - 13			25.0	0.984	29.0	1.142	T2099/3	T2099/5			
1.1/2	14 - 15			26.0	1.024	30.0	1.181	T2103/3	T2103/5			
	16			28.1	1.105	33.0	1.299	T2111/3	T2111/5			
	10 - 12			31.0	1.221	35.0	1.378	T2118/3	T2118/5			
1.3/4	13 - 16			33.0	1.300	38.0	1.496	T2126/3	T2126/5			
	8 - 9	2	3	35.0	1.379	40.0	1.575	T2134/3	T2134/5	T2134/7	T2134/9	T2134/11
	10 - 12	2	4 - 5	37.0	1.457	42.5	1.673	T2142/3	T2142/5	T2142/7	T2142/9	T2142/11
2	13 - 16	2	6	39.0	1.536	44.5	1.752	T2150/3	T2150/5	T2150/7	T2150/9	T2150/11
	7 - 9	2.1/4	3	41.0	1.615	47.0	1.850	T2158/3	T2158/5	T2158/7	T2158/9	T2158/11
	10 - 12	2.1/4	4 - 5	43.0	1.694	49.0	1.929	T2166/3	T2166/5	T2166/7	T2166/9	T2166/11
	13 - 16	2.1/4	6	45.0	1.772	51.5	2.027	T2174/3	T2174/5	T2174/7	T2174/9	T2174/11
2.1/4	16	2.1/2	3	47.0	1.851	54.0	2.126	T2181/3	T2181/5	T2181/7	T2181/9	T2181/11
	10 - 13	2.1/2	4 - 5	49.0	1.930	56.0	2.205	T2189/3	T2189/5	T2189/7	T2189/9	T2189/11
	14 - 16	2.1/2	6	51.0	2.009	60.0	2.362	T2197/3	T2197/5	T2197/7	T2197/9	T2197/11
2.1/2	7 - 10			53.0	2.087	62.0	2.441	T2205/3	T2205/5	T2205/7	T2205/9	T2205/11
	11 - 13	3	2	55.0	2.116	64.0	2.520	T2213/3	T2213/5	T2213/7	T2213/9	T2213/11
	14 - 16			57.0	2.245	66.0	2.598	T2221/3	T2221/5	T2221/7	T2221/9	T2221/11

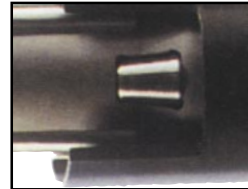

SPARE ROLLER SET MODEL					SPARE MANDREL MODEL		
Tube Sheet Thickness Range					Drum Type 2.3/4"	Short Series Mandrels	SQ ☐
1/2" to 3/4"	7/8" to 3/4"	1.3/8" to 1.1/4"	1.7/8" to 1.3/4"	2.3/8" to 2.1/4"			
3	5	7	9	11			
0793-FS	0795-FS				TM-83		1/2" ☐
0833-FS	0835-FS						
0873-FS	0875-FS				TM-91		
0953-FS	0955-FS						
0953-FS	0955-FS				TM-99		
0993-FS	0995-FS						
1033-FS	1035-FS						
1113-FS	1115-FS				TM-118	TMS-1,2,3	3/4" ☐
1183-FS	1185-FS						
1263-FS	1265-FS				TM-126	TMS-2,3,4	
1263-FS	1265-FS	1267-FS	1269-FS	12611-FS	TM-134	TMS-3,4,5	
1423-FS	1425-FS	1427-FS	1429-FS	14211-FS	TM-150	TMS-3,4,5,6	
1503-FS	1505-FS	1507-FS	1509-FS	15011-FS			
1583-FS	1585-FS	1587-FS	1589-FS	15811-FS	TM-174	TMS-4,5,6,7,8	
1663-FS	1665-FS	1667-FS	1669-FS	16611-FS			1" ☐
1743-FS	1745-FS	1747-FS	1749-FS	17411-FS			
1813-FS	1815-FS	1817-FS	1819-FS	18111-FS	TM-197	TMS-7,8,9,10,11	
1743-FS	1745-FS	1747-FS	1749-FS	17411-FS			
2053-FS	2055-FS	2057-FS	2059-FS	20511-FS		TMS-6,7,8,9,10,11	
2053-FS	2055-FS	2057-FS	2059-FS	20511-FS	TM-221	TMS-7,8,9,10,11,12	
2133-FS	2135-FS	2137-FS	2139-FS	21311-FS			

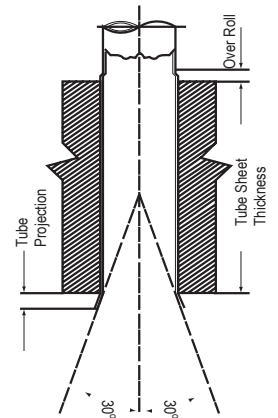

'T - 2000' Series [Flare] Boiler Tube Expander

3 Plain Rollers

3 Flare Rollers

- ❑ Controlled travel of expander
- ❑ Positive depth setting
- ❑ Uniform tight joints
- ❑ In-built thrust bearing

Tristar offers solutions to overcome any installation problem.

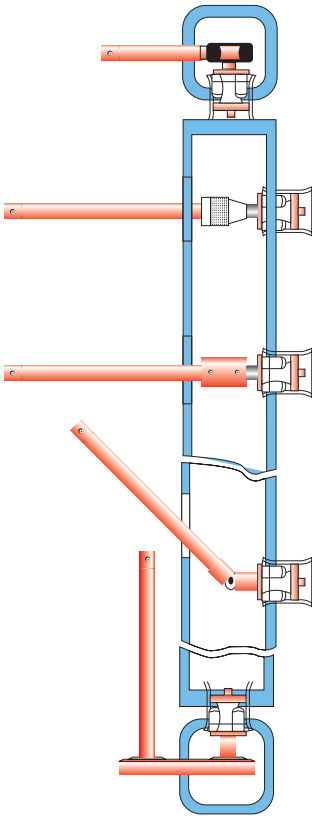

The various drive accessories developed are designed for optimum productivity and operator ease

TUBE SIZE				Min I.D. Tool Enters		Max Expansion of Tool		TUBE EXPANDER MODEL				
								Tube Sheet Thickness Range				
O.D. inch	THK bwg	O.D. inch	THK bwg	mm	inch	mm	inch	1/2" to 3/4"	7/8" to 1.1/4"	1.3/8" to 1.3/4"	1.7/8" to 2.1/4"	2.3/8" to 2.3/4"
				Tube Sheet Thickness Codes >				3	5	7	9	11
2.3/4	7 - 9			59.0	2.323	68.0	2.677	T2229/3	T2229/5	T2229/7	T2229/9	T2229/11
	10 - 12			61.0	2.402	70.0	2.756	T2237/3	T2237/5	T2237/7	T2237/9	T2237/11
	13 - 16			63.0	2.481	72.0	2.835	T2244/3	T2244/5	T2244/7	T2244/9	T2244/11
3	7 - 8			65.0	2.560	74.0	2.913	T2252/3	T2252/5	T2252/7	T2252/9	T2252/11
	10 - 12			67.0	2.638	76.0	2.992	T2260/3	T2260/5	T2260/7	T2260/9	T2260/11
	13 - 14			69.0	2.717	78.0	3.071	T2268/3	T2268/5	T2268/7	T2268/9	T2268/11
	15 - 16			71.0	2.796	80.0	3.150	T2276/3	T2276/5	T2276/7	T2276/9	T2276/11
3.1/4	7 - 11			73.0	2.874	82.0	3.228	T2284/3	T2284/5	T2284/7	T2284/9	T2284/11
	12 - 14			75.0	2.953	84.0	3.307	T2292/3	T2292/5	T2292/7	T2292/9	T2292/11
	15 - 16	3.1/2	7 - 9	77.0	3.032	86.0	3.386	T2300/3	T2300/5	T2300/7	T2300/9	T2300/11
3.1/2	10 - 12			79.0	3.111	88.0	3.465	T2308/3	T2308/5	T2308/7	T2308/9	T2308/11
	13 - 15			81.0	3.190	92.0	3.622	T2315/3	T2315/5	T2315/7	T2315/9	T2315/11
	16	3.3/4	7 - 8	83.0	3.268	94.0	3.701	T2323/3	T2323/5	T2323/7	T2323/9	T2323/11
3.3/4	9 - 12			85.0	3.347	96.0	3.780	T2331/3	T2331/5	T2331/7	T2331/9	T2331/11
	13 - 16			87.0	3.426	98.0	3.858	T2339/3	T2339/5	T2339/7	T2339/9	T2339/11
4	7 - 8			89.0	3.505	100.0	3.937	T2347/3	T2347/5	T2347/7	T2347/9	T2347/11
	9 - 12			91.0	3.583	102.0	4.016	T2355/3	T2355/5	T2355/7	T2355/9	T2355/11
	13 - 15			93.0	3.662	104.0	4.094	T2363/3	T2363/5	T2363/7	T2363/9	T2363/11
	16	4.1/4	7 - 8	95.0	3.741	106.0	4.173	T2370/3	T2370/5	T2370/7	T2370/9	T2370/11
4.1/4	9 - 11			97.0	3.820	108.0	4.252	T2378/3	T2378/5	T2378/7	T2378/9	T2378/11
	12 - 16			99.0	3.898	110.0	4.331	T2386/3	T2386/5	T2386/7	T2386/9	T2386/11
	7 - 14			101.0	3.997	111.0	4.407	T2394/3	T2394/5	T2394/7	T2394/9	T2394/11



SPARE ROLLER SET MODEL					SPARE MANDREL MODEL		
Tube Sheet Thickness Range					Drum Type	Short Series Mandrels	SQ
1/2" to 3/4"	7/8" to 1.1/4"	1.3/8" to 1.3/4"	1.7/8" to 2.1/4"	2.3/8" to 2.3/4"			
3	5	7	9	11			
2213-FS	2215-FS	2217-FS	2219-FS	22111-FS	TMP-244	TMPS-8,9,10,11,12,13	1"
2373-FS	2375-FS	2377-FS	2379-FS	23711-FS			
2523-FS	2525-FS	2527-FS	2529-FS	25211-FS			
2523-FS	2525-FS	2527-FS	2529-FS	25211-FS	TMP-268	TMPS-10,11,12,13,14	
2603-FS	2605-FS	2607-FS	2609-FS	26011-FS			
2683-FS	2685-FS	2687-FS	2689-FS	26811-FS			
2763-FS	2765-FS	2767-FS	2769-FS	27611-FS	TMP-300	TMPS-12,13,14,15,16	
2843-FS	2845-FS	2847-FS	2849-FS	28411-FS			
2923-FS	2925-FS	2927-FS	2929-FS	29211-FS			
3153-FS	3155-FS	3157-FS	3159-FS	31511-FS			
2843-FS	2845-FS	2847-FS	2849-FS	28411-FS	TMP-347	TMPS-15,16,17,18,19	
3153-FS	3155-FS	3157-FS	3159-FS	31511-FS		TMPS-14,15,16,17,18,19	
3233-FS	3235-FS	3237-FS	3239-FS	32311-FS			
3313-FS	3315-FS	3317-FS	3319-FS	33111-FS			
3553-FS	3555-FS	3557-FS	3559-FS	35511-FS			
3633-FS	3635-FS	3637-FS	3639-FS	36311-FS			
3553-FS	3555-FS	3557-FS	3559-FS	35511-FS	TMP-394	TMPS-17,18,19,20,21	
3633-FS	3635-FS	3637-FS	3639-FS	36311-FS			
3703-FS	3705-FS	3707-FS	3709-FS	37011-FS			
3783-FS	3785-FS	3787-FS	3789-FS	37811-FS			
3863-FS	3865-FS	3867-FS	3869-FS	38611-FS			
3943-FS	3945-FS	3947-FS	3949-FS	39411-FS			

